



CM41

Modbus Plus Module

Features

- Two Read/Write RFID Antenna Ports
- 25 MHz i386 Processor
- 512KB Flash Memory
- 512KB RAM
- DOS Compatible Operating System
- Two General Purpose Serial Ports for CM41
- One Industrial-Level Input
- LED Status Indicators
- NEMA 4 (IP66) Enclosure
- Supports Modbus Plus Cable Redundancy at A and B Ports

Applications

- Material Handling
- Sortation Systems
- Work-in-Progress Monitoring
- Quality Control

Use With

- EMS Passive Read/Write
- EMS Passive Read Only
- EMS Active Read/Write
- RS232 and RS422 Serial Devices

EMS, a Datalogic Group Company, is the field-proven leader in the development and application of Radio Frequency Identification (RFID) Tags/Labels/PCBs, Antennas, Controllers and network interface modules for tough industrial environments. With over a dozen years of RFID successes in the automotive, electronics, material handling and food processing industries, EMS has built a global reputation in providing customers with complete supply chain solutions – from production to retail EMS has the complete solution!

Technical Description

The CM41 Modbus Plus module is a general purpose programmable interface between the Modbus Plus network and up to two HS/HL500-Series Antennas, or as many as 32 HMS-Series Reader/Writers, RS-Series Readers or bar code scanners (or a combination of both) on a Mux32 line.

The CM41 can be used to give a Modbus Plus presence to a wide range of existing equipment, such as bar code readers, RFID Controllers, bar code verifiers, sensors and switches. A PLC can communicate to the CM41 using the MSTR function block. An al-

ternate form of communication is a PC-based master such as Modicon's SA85, which can use the Modicon DOS or Windows driver to communicate with the CM41.

This programmable interface is provided with a standard program that allows Modbus Plus commands to control the reading and writing of a block (or non-contiguous blocks) of data, Mux32 connection status, serial inputs/outputs, and Tag fill functions. The standard program can readily be modified by EMS. For special applications; contact your EMS representative.

The CM41 is based on a real-time, DOS compatible operating system providing great speed and flexibility. As many as eight commands can be processed simultaneously. The CM41 is implemented as a two board set, interconnected by a stackable PC104 Connector.

**MODBUS PLUS
PRESENCE
FOR
AUTO ID
PRODUCTS**

CM41 Modbus Plus Module

Electrical	Power Requirements From External Connector	24VDC \pm 15% 350mA (Module Only) 900mA (with Antennas)
Communication	Modbus Plus RFID	Slave Device, 16 Bit Registers, Dual Redundant Bus Two EMS HS/HL-Series Antenna Ports, HMS-Series through Serial Ports
Ports	COM1 COM2 Input	RS232 RS232/RS422/RS485(Mux32 Protocol) One Industrial-Level Input, 10-30VDC
Mechanical Specifications	Dimensions (L x W x H) Weight Enclosure	8.66 x 4.72 x 3.83in. (220 x 120 x 97mm) 3.5lbs. (1.6kg) Aluminum Alloy
Environment	Operating Temperature Storage Temperature Humidity Shock Resistance Vibration Resistance Protection Class	32° to 120°F (0° to 49°C) -4° to 158°F (-20° to 70°C) 90% Non-Condensing IEC 68-2-27 Test EA 30g; 11ms; 3 Shocks Each Axis IEC 68-2-6 Test FC 1.5mm; 10-55Hz; 2 Hours Each Axis NEMA 4 (IP66)

Mechanical Dimensions

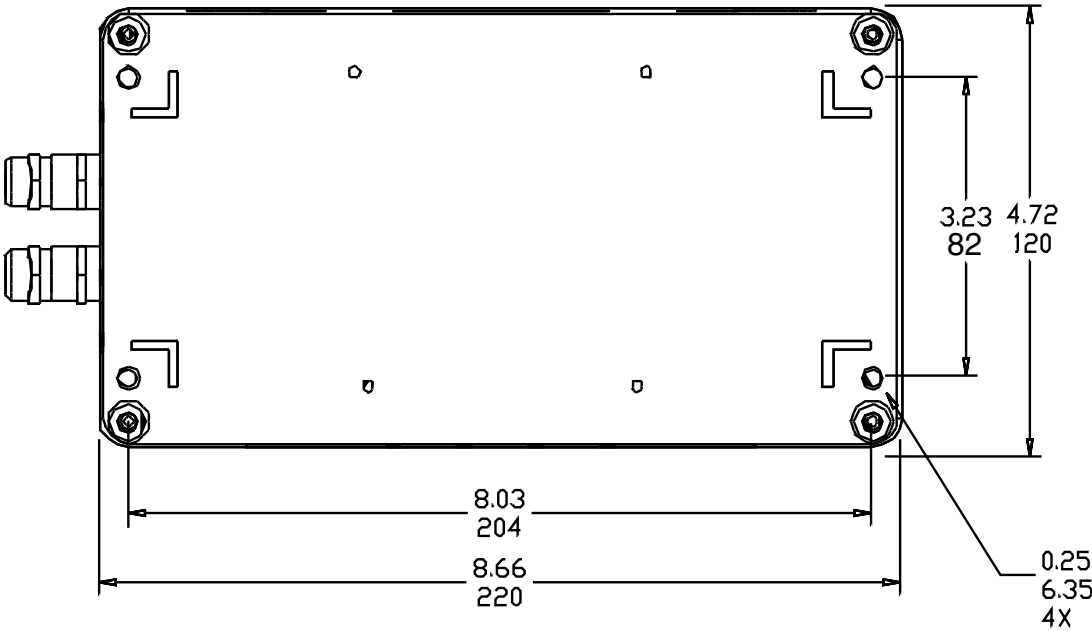
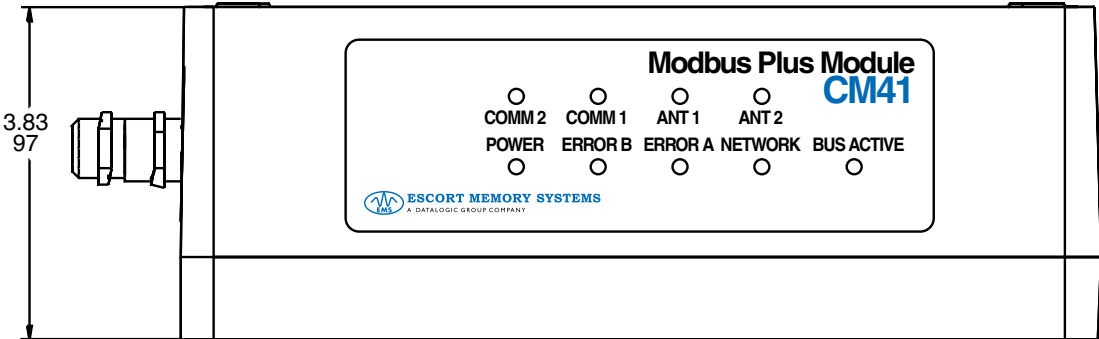

CM41 Modbus Plus Module

Connections

CM41 Modbus Plus Module

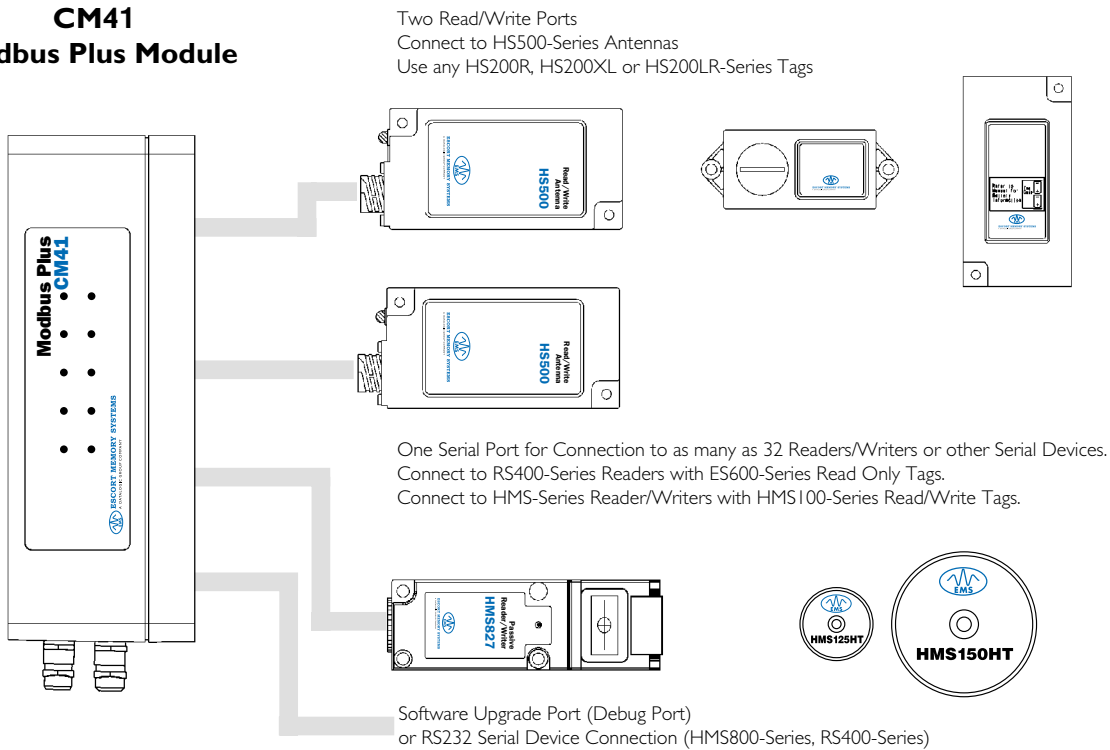

Available Models

Model	Description
CM41	Modbus Plus Communication Module, NEMA 4 (IP66)
CM42	Modbus Plus Communication Module, NEMA 2 (IP31)

Accessories

Model	Description
CBL-1439-01	CM41 to HS500 Cable (1 meter length)
CBL-1439-03	CMx1 to HS500 Cable (3 meter length)
CBL-1439-06	CMx1 to HS500 Cable (6 meter length)
CBL-1439-30	CMx1 to HS500 Cable (30 meter length)