

*DeviceNet™*

CM11 / CM12 DeviceNet Interface Modules

Features

- One Full Duplex RS232, RS485(Mux32), or RS422 Serial Port
- One Programming/ Configuration Port
- One Sensor Port with One Optically Isolated Output
- External or CAN Bus Power
- LED Indicators for Network and Serial Communications Status
- 32KB EEPROM Program Memory and 32KB Static RAM Data Memory
- Hardware Watchdog Timer

Applications

- Material Handling
- Sortation Systems
- Work-in-Progress Monitoring
- Quality Control

Use With

- EMS Passive Read/Write
- EMS Passive Read Only
- EMS Active Read/Write
- Any RS232 Serial Device
- HL-Series

EMS, a Datalogic Group Company, is the field-proven leader in the development and application of Radio Frequency Identification (RFID) Tags/Labels/PCBs, Antennas, Controllers and network interface modules for tough industrial environments. With over a dozen years of RFID successes in the automotive, electronics, material handling and food processing industries, EMS has built a global reputation in providing customers with complete supply chain solutions – from production to retail EMS has the complete solution!

The CM11 can be used to give a DeviceNet presence to Auto ID equipment such as RFID Controllers, bar code readers/scanners, sensors and switches.

The CM11 interfaced to a DeviceNet program allows all of EMS' RS232 devices (as well as other RS232 devices) to have a direct presence on the DeviceNet CAN Bus. As many as 32 serial devices may be attached via the Mux32 RS485 bus.

Technical Description

To an existing DeviceNet system, the CM11 DeviceNet module is a buffered, full duplex, serial channel. The standard program provides a buffered pass-through of serial data. The converter buffers incoming serial data, assembles packets and transmits them over the CAN Bus. Similarly, incoming packets from the CAN Bus are buffered and then transmitted out the serial lines.

One general purpose, opto-isolated, input line is provided for connection of a presence sensor, proximity sensor or relay. The input is passed to the CPU and acted on according to the configuration parameters. The input may be passed back within the CM11 or sent out to the network to be processed by the PLC. An optically-isolated output can be used to send trigger signals or operates as a switch.

EMS' CM12 is an external device that allows an EMS RFID Antenna to interface with the PLC through ODVA's Device-Net network.

The CM12 has one HS500-Series Read/Write Antenna port in addition to one RS232 serial port, which can be used for ASCII data stream transmission and to download updated firmware. An I/O input and output are also provided for sensor control. A standard mini-connector is used for DeviceNet network connections.

The simplified command sets are defined so Read/Write Tag commands can be easily constructed in PLC and communicated through DeviceNet. Power can either be supplied from the DeviceNet network or from an external power source.

**DEVICENET
PRESENCE
FOR
AUTO ID
PRODUCTS**

CM11 / CM12 DeviceNet Interface Modules

CM11 DeviceNet Interface Module

Electrical	Supply Voltage	24VDC \pm 15%
	Current Consumption	90mA max.@24VDC No Connected Devices
Serial Interface	Serial Port Type	RS232, RS422, RS485, Mux32
	Baud Rate	300, 600, 1200, 2400, 4800, 9600, 19200
	Parity	Odd, Even, None
	Data Bits	7 or 8
	Stop Bits	1
	Max. Cable Length	50ft. (15m) RS232 1000ft. (300m) RS422, RS485, Mux32
Mechanical Specifications	Dimensions (W x H x D)	4.92 x 3.15 x 2.21in. (125 x 80 x 56mm)
	Enclosure	Aluminum
	Cables	User Supplied
Environment	Operating Temperature	32° to 120°F (0° to 49°C)
	Storage Temperature	-40° to 185°F (-40° to 85°C)
	Humidity	95% Non-Condensing
	Protection Class	NEMA 4 (IP66)
Input/Output	Input	One Industrial-Level Input, 10-30VDC
	Output	One Industrial-Level Output, 10-30VDC

Mechanical Dimensions

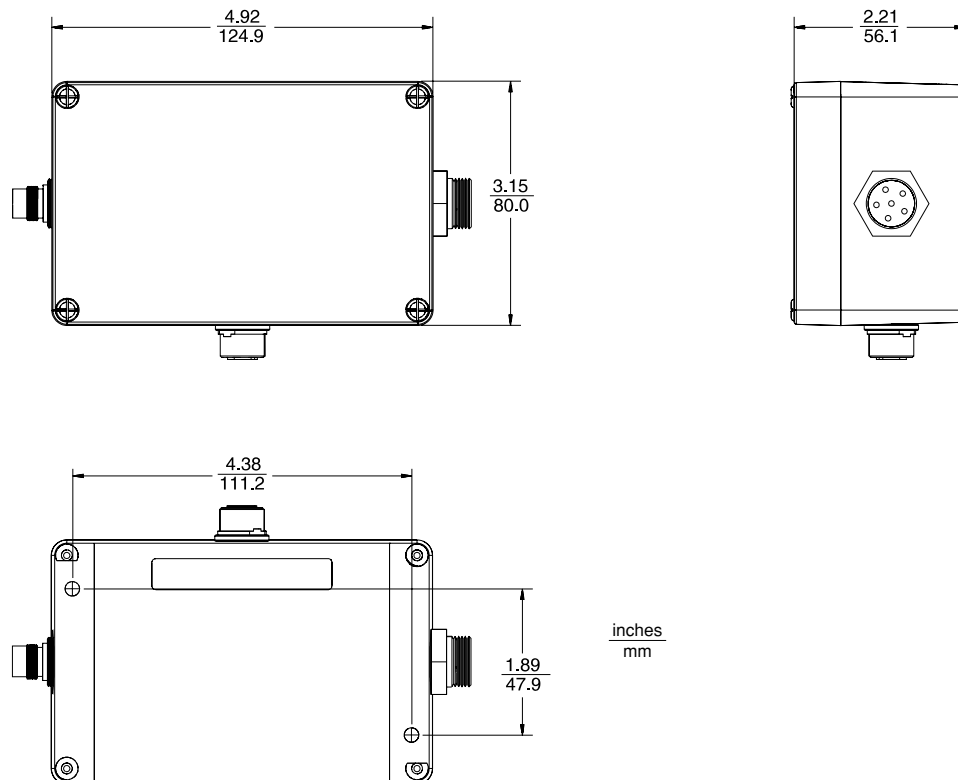

CM11 / CM12 DeviceNet Interface Modules

CM12 DeviceNet Interface Module

Electrical	Supply Voltage	24VDC@250mA max
	Maximum Ripple	2% of Supply Voltage
	Current Consumption	120mA max.@24VDC with No Connected Devices 2.35mA max.@24VDC with HS500 Antenna
Serial Interface	Serial Port Type	RS232
	Baud Rate	9600
	Parity	Odd, Even, None
	Data Bits	8
	Stop Bits	1
	Max. Cable Length	50ft. (15m)
Mechanical Specifications	Dimensions (W x H x D)	4.92 x 3.15 x 2.21in. (125 x 80 x 56mm)
	Enclosure	Aluminum
	Cables	User Supplied
Environment	Operating Temperature	32° to 120°F (0° to 49°C)
	Storage Temperature	-40° to 185°F (-40° to 85°C)
	Humidity	95% Non-Condensing
	Protection Class	NEMA 4 (IP66)
Input/Output	Input	One Industrial-Level Input, 10-30VDC
	Output	One Industrial-Level Output, 10-30VDC

Mechanical Dimensions

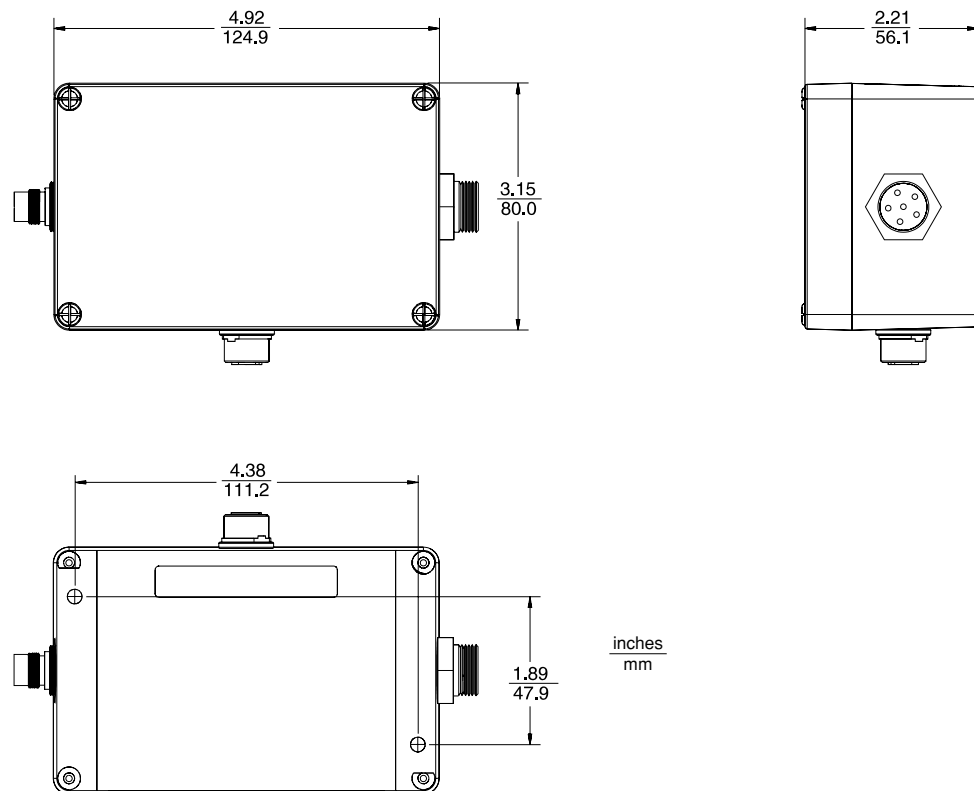

CM11 / CM12 DeviceNet Interface Modules

Available Models

Model	Description
CM11	DeviceNet Interface Module, HMS-Series
CM12	DeviceNet Interface Module, HS500-Series

Accessories

Model	Description
88-1001	Franklin C-Compiler for CM11 software development
CBL-1222	Programming/Debug Cable, CM11 to PC
CBL-1224	Unterminated Cable, CM11, 3 ft. length
CBL-1226	CM11 to RS427-10 Demonstration Cable, 18" length
46-1377	Terminal Plug for AB 1747SDN DeviceNet module
00-1062	Demonstration Kit, includes: CBL-1222, CBL-1224, CBL-1226, 46-1377
46-1089	Mating Connector to RS232 port (right angle)
46-1357	Mating Connector to sensor port
46-1393	Mating Connector to DeviceNet